

16VG32

Bore 320 mm, Stroke 480 mm

Main Data					
Speed	750 rpm		720 rpm		
Frequency	50 Hz		60 Hz		
Model	Genset. kw	Engine. kw	Genset. kw	Engine. kw	
GC7450LA	-	-	7,450	7,680	
GC7760LA	7,760	8,000	-	-	
Based on alternator efficiency of 97%.					
Specific Consumption					
100% Load	Unit		Engine	Genset	
Fuel Oil Consumption	g/kWh		189	195.9	
Lube oil consumption	g/kWh		0.8	0.82	
Dimensions					
Speed	Cyl.	Dimensions (mm) ¹⁾			Dry Mass (ton) ²⁾
		L	B	H	Genset ^{1),3)}
	16	12,900	2,860	4,390	110.5

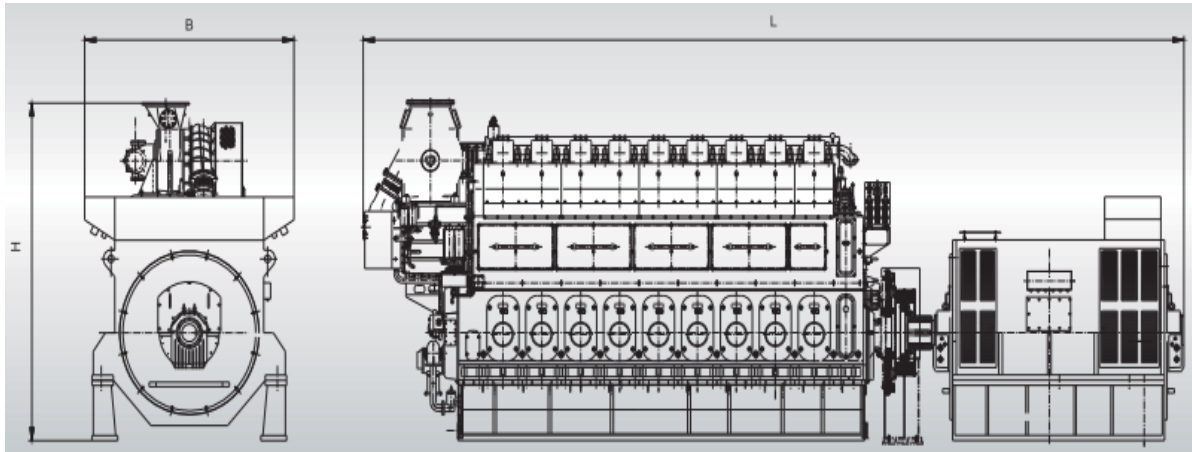

Remarks:

- 1) Depending on alternator.
- 2) Weight included a standard alternator (Maker: GDF).
- 3) With common base frame & alternator.

Note) All dimensions and weight are approximate value and subject to change without prior notice.

URL: <http://www.soarpower.com>

E-mail: sale@soarpower.com

Phone: +86-4008111308